

# 2-PC Full Port SS Ball Valve

**FLOW+ B01**

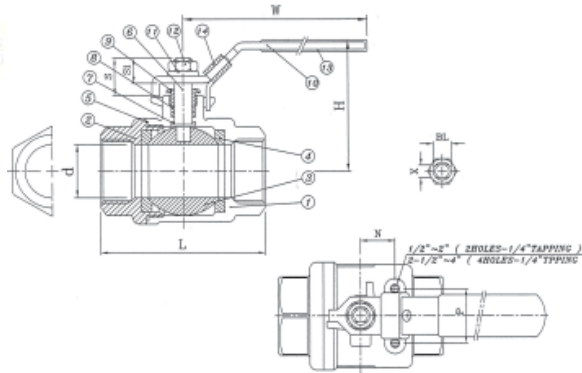

No	Parts for B01	Qty	Material
01	Body	1	ASTM-CF8M-A351
02	End Cap	1	ASTM-CF8M-A351
03	Ball	1	ASTM-CF8M-A351
04	Ball Seat	2	15% R-PTFE
05	Joint Gasket	1	PTFE
06	Stem	1	AISI 316
07	Thrust Washer	1	PTFE
08	Stem Packing	2	PTFE
09	Gland Nut	1	AISI 304
10	Handle	1	AISI 304
11	Spring Washer	1	AISI 304
12	Stem Nut	1	AISI 304
13	Handle Sleeve	1	Vinyl Grip
14	Lock Device	1	AISI 304

**Pressure rating:**  
 - 1000 psi (69 Bar)  
 WOG for 1/4" to 2"

- Features:
- Investment Cast Body and Cap
  - Blow-out proof stem / Full Port
  - FNPT threaded on both ends
  - Material: ASTM A351-CF8M
  - Locking Handle

Size	dia (mm)	L	H	W	S	S1	X	N	P	BL	Cv Factor	Wt kg
1/4"	11.6	44.5	51	95	16.8	10.2	5	12.5	25	5/16"	7	0.21
3/8"	12.7	44.5	51	95	16.8	10.2	5	12.5	25	5/16"	7	0.22
1/2"	15	57	53	95	16.8	10.2	5	12.5	25	5/16"	15	0.29
3/4"	20	65	59.5	110	21	13.5	6.5	21	24	3/8"	45	0.42
1"	25.4	76	73	135	24	16	8	22.5	33.5	7/16"	65	0.71
1-1/4"	32	87.5	79	135	25	16	8	23.5	38.1	7/16"	125	1.06
1-1/2"	38	102	90.5	165	26.5	17	9	23.5	38.1	1/2"	175	1.68
2"	50.8	123	98.5	165	26.5	17	9	23.5	38.1	1/2"	380	2.71

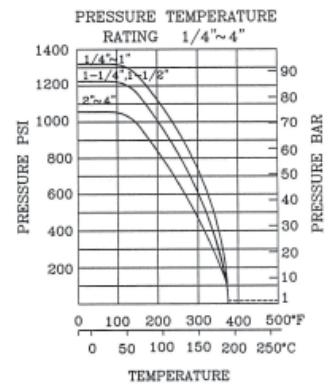

# 2-PC Full Port SS Ball Valve

**FLOW+ B02**

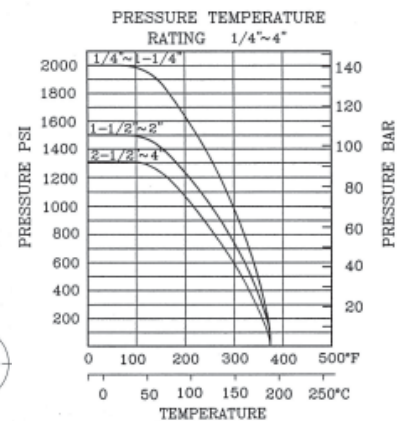
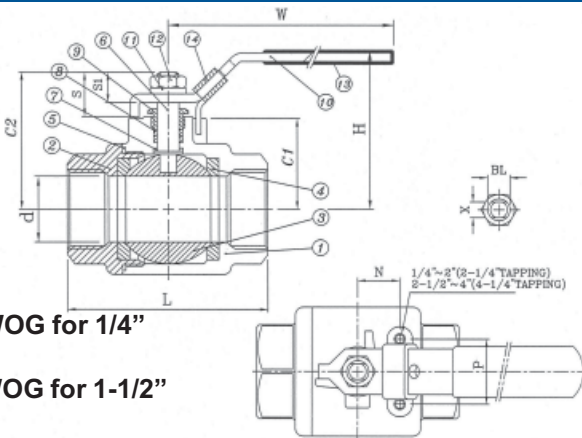

**Pressure rating:**  
 - 2000 psi (137.8 Bar) WOG for 1/4" to 1-1/4"  
 - 1500 psi (103.4 Bar) WOG for 1-1/2" to 2"  
 - 1300 psi (89.6 Bar) WOG for 2-1/2" to 4"

- Features:
- Investment Cast Body and Cap
  - Blow-out proof stem / Full Port
  - FNPT threaded on both ends
  - Locking Handle
  - Material: ASTM A351-CF8M

Size	dia (mm)	L	H	W	S	S1	X	N	P	C1	C2	BL	Cv Factor	Wt (kg)
1/4"	11.6	60.5	53	105	16.5	10.2	5	12.5	28.5	26	42.5	5/16"	7	0.3
3/8"	12.7	60.5	53	105	16.5	10.2	5	12.5	28.5	26	42.5	5/16"	7	0.3
1/2"	15	62.5	53	105	16.5	10.2	5	12.5	28.5	26	42.5	5/16"	15	0.35
3/4"	20	77	60	125	20	13.5	6.5	21	34.8	32.2	52.3	3/8"	45	0.58
1"	25.4	90	74	160	23.5	16	8	22.5	34.8	39.2	63.1	7/16"	65	1.04
1-1/4"	32	100	80	160	23.5	16	8	23.5	38.1	45.3	68.7	7/16"	125	1.54
1-1/2"	38	118	92	190	25.5	17	9	23.5	38.1	53.4	78.9	1/2"	175	2.3
2"	50.8	138	101	190	25.5	17	9	34	38.1	62.6	88.2	1/2"	380	3.8

No	Parts for B02	Qty	Material
01	Body	1	ASTM-CF8M-A351
02	End Cap	1	ASTM-CF8M-A351
03	Ball	1	ASTM-CF8M-A351
04	Ball Seat	2	15% R-PTFE
05	Joint Gasket	1	PTFE
06	Stem	1	AISI 316
07	Thrust Washer	1	PTFE
08	Stem Packing	2	PTFE
09	Gland Nut	1	AISI 304
10	Handle	1	AISI 304
11	Spring Washer	1	AISI 304
12	Stem Nut	1	AISI 304
13	Handle Sleeve	1	Vinyl Grip
14	Lock Device	1	AISI 304

\*Note: available in Carbon Steel as model B11 on page

Sizes and Specifications shown are subject to change without notice.

# 2-PC Full Port SS Ball Valve - Direct Mount\*

**FLOW+** B03

\* See Page 14 for Actuation

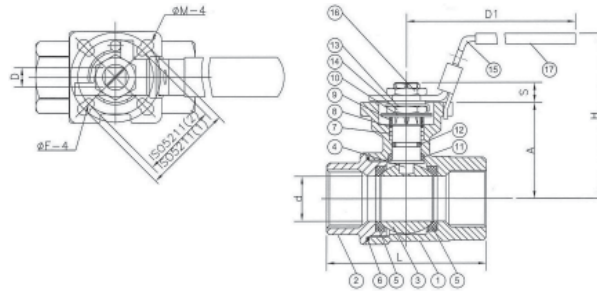

Pressure rating: 1000 psi (69 Bar)  
WOG for 1/4" to 2"

High Cycle, Live Loaded, Triple Stem  
Seal comprising of:

- Carbon Filled PTFE Wedge Ring Thrust Washer
- Viton O-Ring
- 15% RTFE Chevron packing
- Live loaded Belleville Washers
- Packing Nut Mechanically Locked to Stem

Features:

- Investment Cast body and cap
- Blow-out proof stem / Full port
- Direct Mounting Pad for ISO Std 5211
- FNPT threaded on both ends
- Material: ASTM A351-CF8M (316SS)

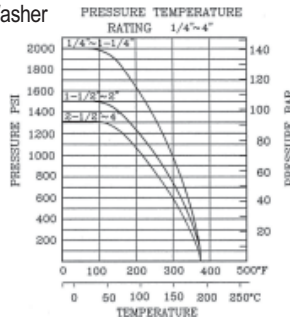

No	Parts	Material
01	Body	ASTM-A351Gr.CF8M
02	End Cap	ASTM-A351Gr.CF8M
03	Ball	ASTM-A351Gr.CF8M
04	Stem	S.S. 316
05	Ball Seat	15% RTFE
06	Gasket	15% RTFE
07	Stem Packing	15% RTFE
08	Thrust Washer	15% RTFE
09	Stem Packing	S.S. 304
10	Belleville Washer	SUS 304-USP
11	Thrust Washer	PTFE + 25% Carbon
12	O-ring	Viton
13	Locking Washer	S. S. 304
14	Stem Nut	S.S. 304
15	Handle	S.S. 304
16	Handle Nut	S.S. 304
17	Handle Cover	Vinyl Grip

Size	dia (mm)	L	F	M	ISO 5211	Torque in - lb	D	H	D1	S	A	Cv	Wt (kg)
1/2"	15	65.3	6	7.5	42 50	85	9	72.85	112	8.5	36.95	15	0.46
					F04 F05								
3/4"	20	77.3	7.5	9.5	50 70	110	9	81.8	112	8.5	45	45	0.81
					F05 F07								
1"	25	88.7	7.5	9.5	50 70	180	11	90.45	136	11.4	53.45	65	0.96
					F05 F07								
1-1/2"	38	109	7.5	9.5	50 70	315	14	114.7	197.9	14	74.75	175	2.3
					F05 F07								
2"	50	125.3	9.5	11	70 102	450	14	124.0	197.9	13.7	83.5	380	3.2
					F07 F10								

# 3-PC Full Port SS Ball Valve

**FLOW+** B04/B04S

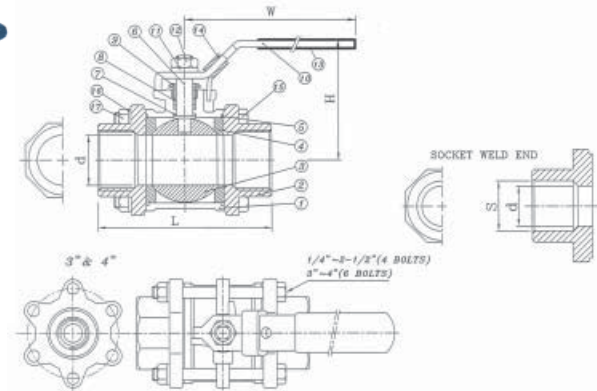

Pressure rating: 1000 psi (69 Bar) WOG for 1/4" to 4"

Features:

- Investment Cast body and cap
- Blow-out proof stem/Full port
- FNPT threaded on both ends for B04
- Socket Weld on both ends for B04S
- Locking Handle
- Material: ASTM A351-CF8M (316SS)

Size	dia (mm)	L	H	W	B	D	S	Cv Factor	Wt
1/4"	11.6	54	51	95	12	18	14.1	10	0.34
3/8"	12.7	54	51	95	12.5	18	17.6	10	0.34
1/2"	15	61.5	55	95	15.8	22	21.7	26	0.46
3/4"	20	71	58.5	110	20.9	28	27.2	50	0.62
1"	25	83.5	73	135	26.6	34	33.9	68	1.96
1-1/4"	32	97	78.5	135	35.05	44	42.6	120	1.49
1-1/2"	38	110.5	90.5	165	40.9	50	48.7	170	2
2"	50	129	99	165	52.5	61.5	61.1	360	3.12
2-1/2"	65	171.5	127	215	69	76	76.9	510	6.5
3"	80	200	136	215	82	90	89.8	900	10.4
4"	100	252	172	325	106	115	115.4	1250	20.2

No	Parts	Qty	Material
01	Body	1	ASTM-CF8M-A351
02	End Cap	1	ASTM-CF8M-A351
03	Ball	1	ASTM-CF8M-A351
04	Ball Seat	2	15% R-PTFE
05	Joint Gasket	1	15% R-PTFE
06	Stem	1	AISI 316
07	Thrust Washer	1	PTFE
08	Stem Packing	2	PTFE
09	Gland Nut	1	AISI 304
10	Handle	1	AISI 304
11	Stem Washer	1	AISI 304
12	Stem Nut	1	AISI 304
13	Handle Sleeve	1	Vinyl Grip
14	Lock Device	1	AISI 304
15	Bolt	4-6	AISI 304
16	Spring Washer	4-12	AISI 304
17	Hex Nut	4-12	AISI 304

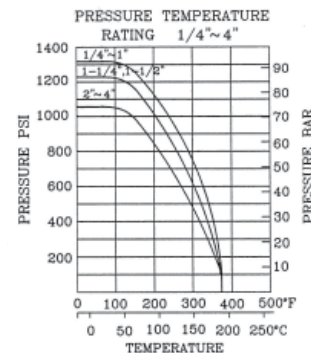

# 3-PC Full Port SS Ball Valve - Direct Mount\*



\* See page 14 for Actuation

Available in Threaded (B05), Socket weld (B05S), and Tri-Clamp (B05TC) ends

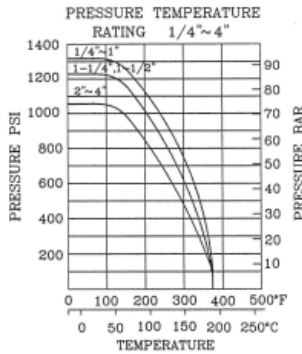
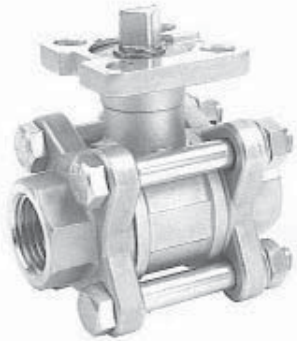

Size	dia (mm)	L	F	M	ISO 5211	Torque in - lbs	D	H	D1	S	A	Cv	Wt (kg)
1/2"	15	63.5	6	7.5	42	85	9	72.85	112	8.5	36.95	26	0.6
					F04								
3/4"	20	72.5	7.5	9.5	50	110	9	80.8	112	8.5	45	50	0.7
					F05								
1"	25	81	7.5	9.5	50	180	11	90.45	136	11.4	53.45	68	1.03
					F05								
1-1/2"	38	108	7.5	9.5	50	315	14	115.25	197.9	14	74.75	170	2.5
					F05								
2"	50	121.5	9.5	11	70	450	14	124.0	197.9	13.7	83.5	360	3.4
					F07								
3"	80	190	11	14.3	102	680	17	208.5	264	18	118.25	900	11.2
					F10								
4"	100	225	11	14.3	102	1190	22	216.7	325	23	153.75	1250	22
					F10								

Pressure rating: 1000 psi (69 Bar) WOG for 1/4" to 4"

High Cycle, Live Loaded, Triple Stem Seal comprising of:

- Carbon Filled PTFE Wedge Ring Thrust Washer and Viton O-Ring
- 15% RTFE Chevron packing
- Live loaded Belleville Washers
- Packing Nut Mechanically Locked to Stem

Features:

- Investment Cast body and cap
- Blow-out proof stem / Full port
- Direct Mounting Pad for ISO Std 5211
- FNPT threaded on both ends on B05
- Socket weld ends on B05S
- Tri-Clamp ends on B05TC
- Material: ASTM A351-CF8M (316SS) and 316LSS Caps on Socket Weld

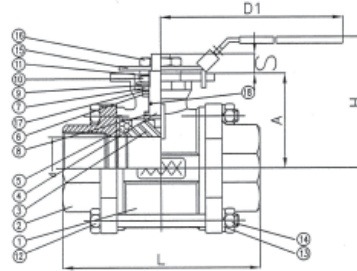
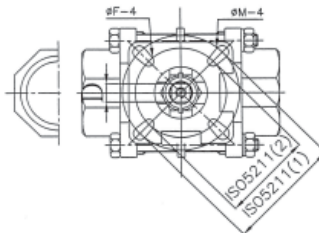

No	Parts	Qty	Material
01	Body	1	ASTM-A351 Gr.CF8M
02	End Cap	2	ASTM-A351 Gr.CF8M
03	Ball	1	ASTM-A351 Gr.CF8M
04	Stem	1	AISI 316
05	Seat	2	15% RTFE
06	Stem Packing	1	15% RTFE
07	Gland Nut	1	AISI 304
08	Thrust Washer	1	PTFE + 25% Carbon
09	Belleville Washer	2	SUS 304-CSP
10	Stem Nut	1	S.S. 304
11	Spring Washer	1	S.S. 304
12	Bolt	4 - 6	S.S. 304
13	Bolt Washers	4 - 6	S.S. 304
14	Bolt Nuts	4 - 6	S.S. 304
15	Handle	1	S.S. 304
16	Handle Nut	1	S.S. 304
17	Stem Ring	1	PTFE + 25% Carbon
18	O-Ring	1	Viton

# 1-PC Reg Port Carbon Steel Ball Valve

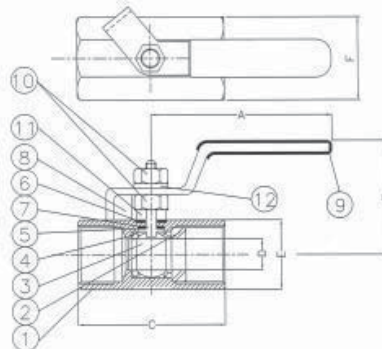

No	Parts for B06	Material (Carbon)
01	Body	A108
02	Insert	A108
03	Ball	AISI 316
04	Seat	PTFE+15%G/F
05	Stem	AISI 316
06	Thrust Washer	PTFE
07	Stem Seal	PTFE
08	Handle	AISI 304
09	Handle Sleeve	Vinyl Grip
10	Nut	304 Stainless Steel
11	Washer	WCB
12	Spring Washer	304 Stainless Steel

Pressure rating: 2000 psi (138 Bar)

Features:

- NACE Trim
- Blow-out proof stem
- FNPT threaded on both ends
- Body material: ASTMA108 Carbon Steel

Size	A	B	C	D	E	F	Wt (kg)	Cv
1/4"	61	29.5	41.3	5	21	24.1	0.21	1.5
3/8"	79	34.5	44	7.2	23	26.4	0.22	3.5
1/2"	108	63	57.2	9.0	29	33.3	0.29	5.7
3/4"	110	65	65.1	12.5	35	40.3	0.42	10
1"	122	68	71	15	41	47.2	0.71	16
1-1/4"	145	79.5	92.1	20	55	63.4	1.06	25
1-1/2"	148	84	98.4	25	57	65.7	1.68	40
2"	148	92.5	114.3	32	73.5	84.7	2.71	62

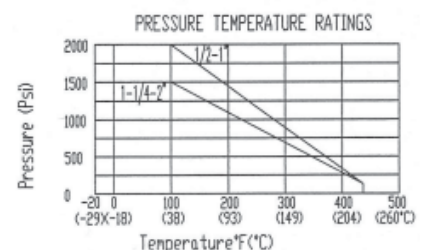

# 3-way Reg. Port SS Ball Valve - Direct Mount\* **FLOW+ B07/LT**

\* See page 14 for Actuation

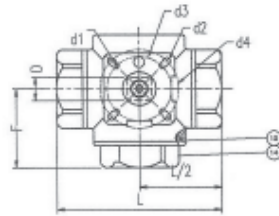
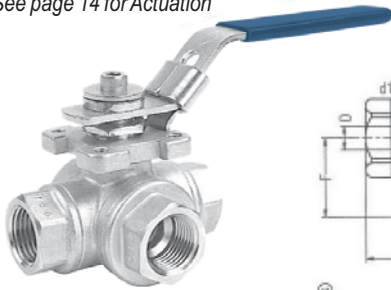

Size	dia (mm)	L	F	ISO 5211	D	H	D1	A	C	d1	d2	H1	W (kg)	Cv
1/2"	12.7	75.7	37.25	42	9	77.45	112	8.5	12	6	7.5	40.65	0.67	6
				F04										
3/4"	16.0	86.6	44.7	50	9	82	112	8.5	12	7.5	9.5	45.2	1.07	8
				F05										
1"	20.0	102.4	51.4	50	11	93.7	136.5	11.4	15.8	7.5	9.5	56.5	1.68	11
				F05										
1-1/2"	32.0	125.8	62.7	50	14	120.25	197.5	14	20.8	7.5	9.5	73.5	3.6	65
				F05										
2"	38.1	149	74.6	70	14	129.85	197.5	13.7	20.8	9.5	11	87.35	5.8	112
				F07										

- Pressure rating: 1000 psi (69 Bar) WOG for 1/4" to 2"  
 High Cycle, Live Loaded, Triple Stem Seal comprising of:
- Carbon Filled PTFE Wedge Ring Thrust Washer
  - Viton O-Ring
  - 15% RTFE Chevron packing
  - Live loaded Belleville Washers
  - Packing Nut Mechanically Locked to Stem

**Features:**

- Anti-static device, L-port, T-port
- Blow-out proof stem
- FNPT end connections
- Locking Handle
- Material: ASTM A351 GR.CF8M (316SS)

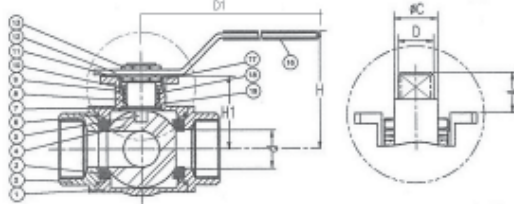

POSITION TYPE	1	2	3	4
L	1 1/2 2/3	1 1/2 2/3		
T	1 1/2 2/3	1 1/2 2/3	1 1/2 2/3	1 1/2 2/3

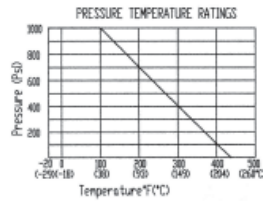

No	Parts	Material
01	Body	ASTM-A351GR.CF8M
02	End Cap	ASTM-A351GR.CF8M
03	Seat	15% RTFE
04	Ball	ASTM-A351GR.CF8M
05	Stem	S. S. 316
06	Gasket	15% RTFE
07	Thrust Washer	PTFE + 25% Carbon
08	Stem Packing	15% RTFE
09	Gland	S.S. 304
10	Belleville Washer	SUS 304-CSP
11	Stem Nut	S. S. 304
12	Handle	S. S. 304
13	Handle Nut	S. S. 304
14	End Cap	ASTM A351 GR.CF8M
15	Gasket	15% RTFE
16	Handle Sleeve	Vinyl Grip
17	Locking Washer	SUS 304-CSP
18	Thrust Washer	PTFE+25% G/F
19	O-Ring	Viton

# 2-PC Full Port Carbon Steel Ball Valve **FLOW+ B11**



Size	dia (mm)	L	H	W	S	S1	X	N	P	C1	C2	BL	Cv Factor	Wt (kg)
1/4"	11.6	60.5	53	105	16.5	10.2	5	12.5	28.5	26	42.5	5/16"	7	0.3
3/8"	12.7	60.5	53	105	16.5	10.2	5	12.5	28.5	26	42.5	5/16"	7	0.3
1/2"	15	62.5	53	105	16.5	10.2	5	12.5	28.5	26	42.5	5/16"	15	0.35
3/4"	20	77	60	125	20	13.5	6.5	21	34.8	32.2	52.3	3/8"	45	0.58
1"	25.4	90	74	160	23.5	16	8	22.5	34.8	39.2	63.1	7/16"	65	1.04
1-1/4"	32	100	80	160	23.5	16	8	23.5	38.1	45.3	68.7	7/16"	125	1.54
1-1/2"	38	118	92	190	25.5	17	9	23.5	38.1	53.4	78.9	1/2"	175	2.3
2"	50.8	138	101	190	25.5	17	9	34	38.1	62.6	88.2	1/2"	380	3.8
2-1/2"	65	167	130	245	41	29.5	12	35	56	77	118.8	3/4"	500	6.8
3"	80	193	142	245	41	29.5	12	35	56	88.8	130.3	3/4"	900	11.6
4"	100	260	174	325	48	36.5	16	50	63	109.6	158.8	1"	1250	23

- Pressure rating:
- 2000 psi (137.8 Bar) WOG for 1/4" to 1-1/4"
  - 1500 psi (103.4 Bar) WOG for 1-1/2" to 3"

**Features:**

- Carbon Steel Body and Cap
- Material: ASTMA216-WCB
- Blow-out proof stem / Full Port
- FNPT threaded on both ends
- Locking Handle

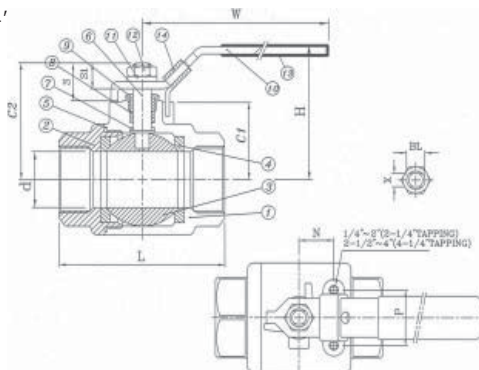

No	Parts for B11	Qty	Material
01	Body	1	ASTM-A216-WCB
02	End Cap	1	ASTM-A216-WCB
03	Ball	1	ASTM-CF8M-A351
04	Ball Seat	2	15% R-PTFE
05	Joint Gasket	1	PTFE
06	Stem	1	AISI 316
07	Thrust Washer	1	15% RTFE
08	Stem Packing	2	15% RTFE
09	Gland Nut	1	AISI 304
10	Handle	1	AISI 304
11	Spring Washer	1	AISI 304
12	Stem Nut	1	AISI 304
13	Handle Sleeve	1	Vinyl Grip
14	Lock Device	1	AISI 304